

### Conjunto de cierre N° 316

- A= Manija Externa 216**
- B= Bloque de cierre 216**
- C= Bloque de cierre 316**
- D= Enganche externo D-64**
- E= Manija interna 216**
- F= Tope interno R-65**

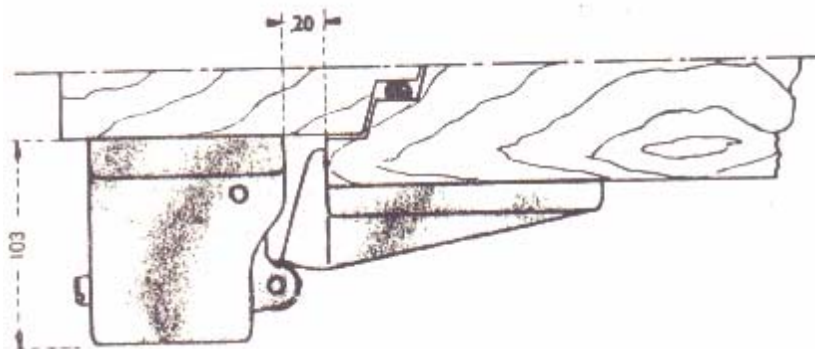
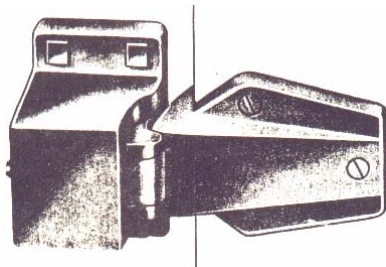
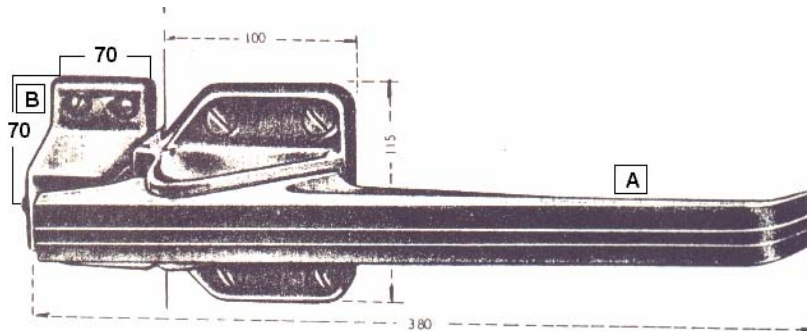

*Contáctenos*